

Schaltplan

Elektro-Bratplatte **EBP7 / V2HT**

[Artikel-Nr.: 406372194]



400V 3/3N~ 50/60Hz 4.2KW 6.1A
 440V 3~ 50/60Hz 4.2KW 5.5A

400V 3/3N~ 50/60Hz 8.4KW 12.2A
 440V 3~ 50/60Hz 8.4KW 11A

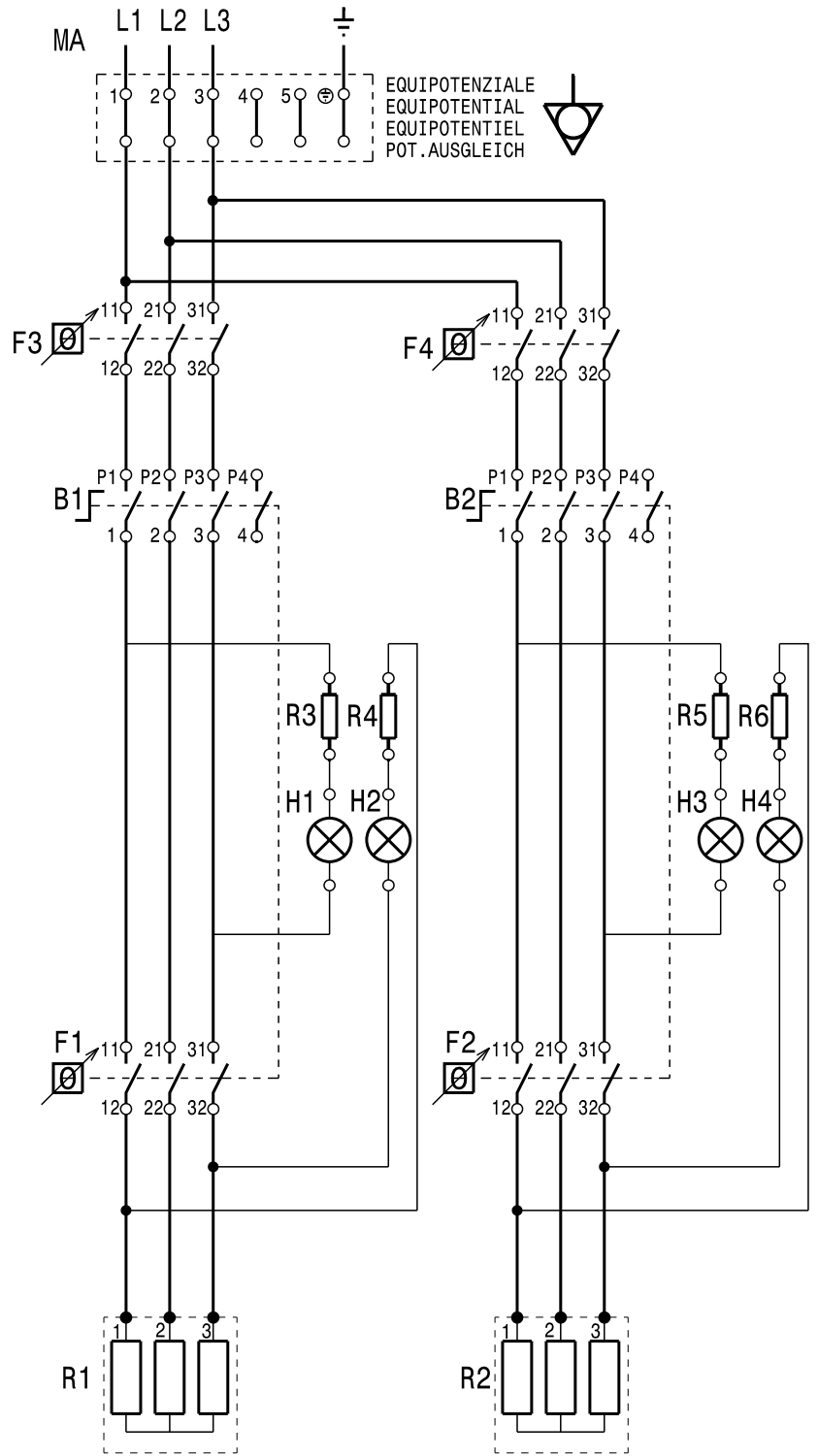
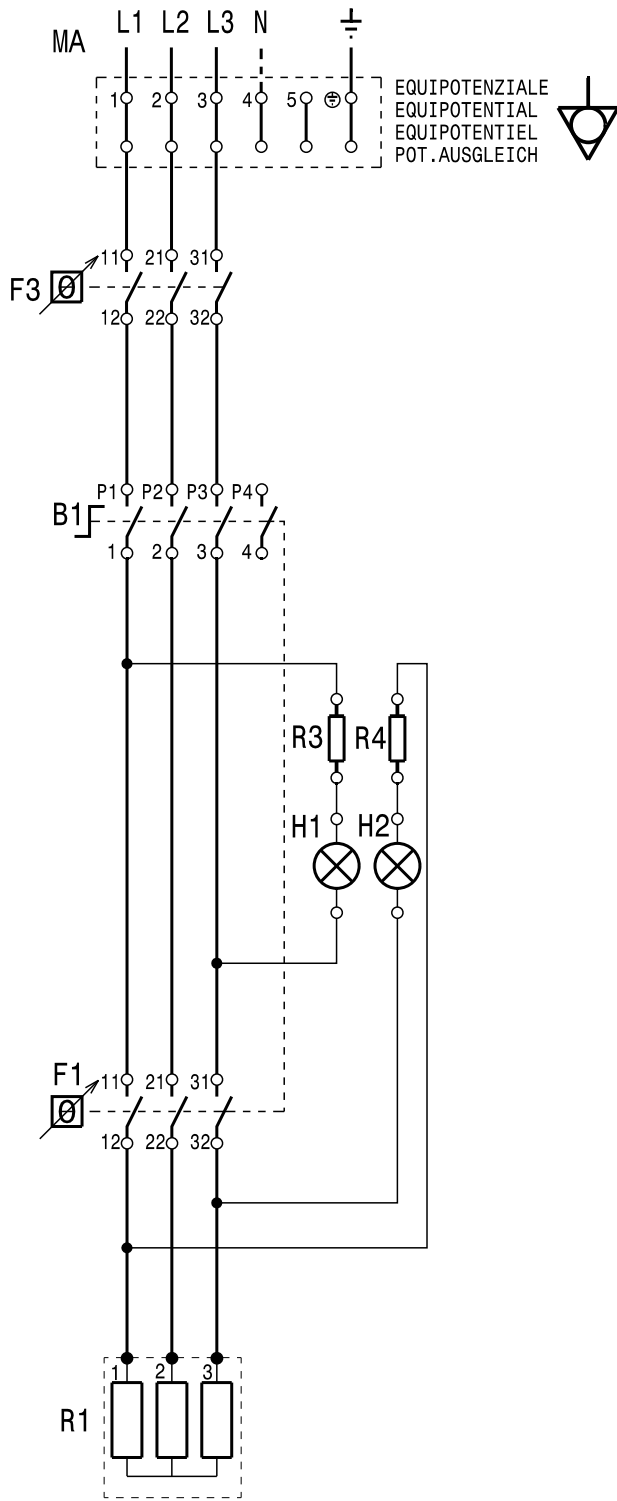

R3-6	RESISTENZA PER LAMPADA	RESISTANCE FOR LAMP
H2-H4	LAMPADA TERMOSTATO	THERMOSTAT LAMP
R1-2	RESISTENZA	HEATING ELEMENTS
H1-H3	LAMPADA "CORRENTE INSERITA"	POWER ON LAMP
F1-2	TERMOSTATO	THERMOSTAT
F3-F4	LIMITATORE DI TEMPERATURA	TEMPERATURE LIMITING THERMOSTAT
B1-2	INTERRUTTORE GENERALE	MAIN SWITCH
MA	MORSETTIERA DI ALLACCIAMENTO	MAIN TERMINAL BOARD

Finanzen/Service

28307 Bremen
Thalendorststraße 15
Tel.+49 421 48557-0
Fax+49 421 488650
bremen@nordcap.de

Vertrieb Ost

12681 Berlin
Wolfener Straße 32/34, HausK
Tel.+49 30 936684-0
Fax+49 30 936684-44
berlin@nordcap.de

Vertrieb West

40699 Erkrath
Max-Planck-Straße 30
Tel.+49 211 540054-0
Fax+49 211 540054-54
erkrath@nordcap.de

Vertrieb Nord

21079 Hamburg
Großmoorbogen 5
Tel.+49 40 766183-0
Fax+49 40 770799
hamburg@nordcap.de

Vertrieb Süd

55218 Ingelheim
Hermann-Bopp-Straße 4
Tel.+49 6132 7101-0
Fax+49 6132 7101-20
ingelheim@nordcap.de



www.nordcap.de