

FOOD PROBE

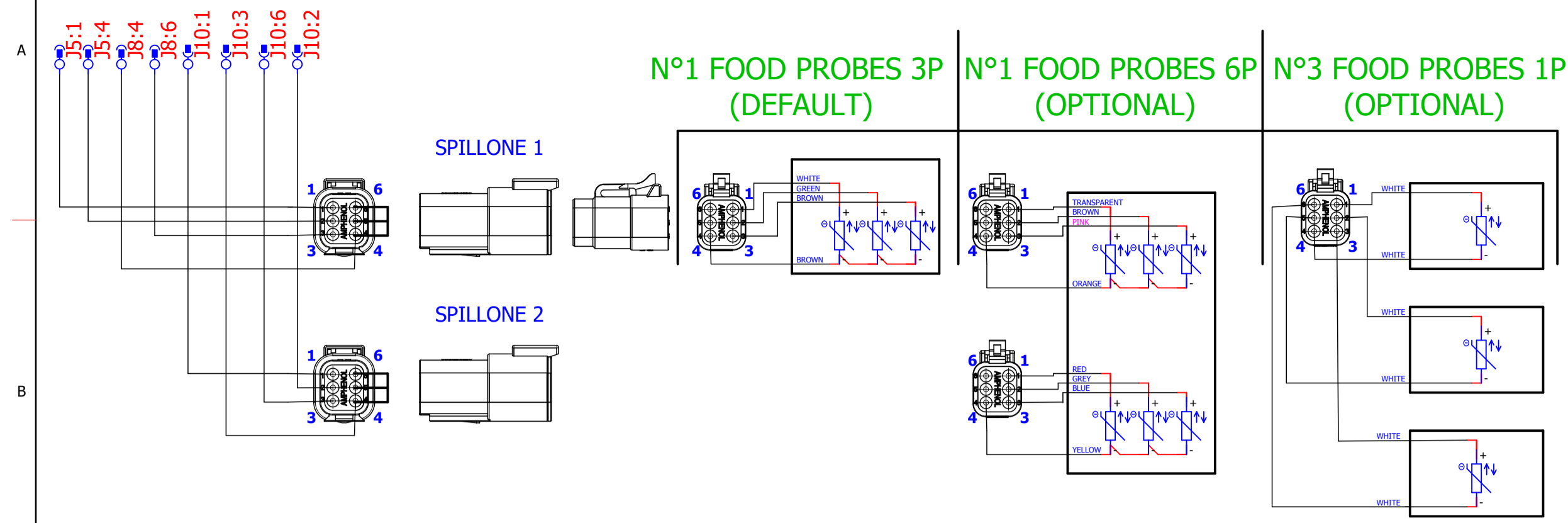

UV LAMP (OPTIONAL)

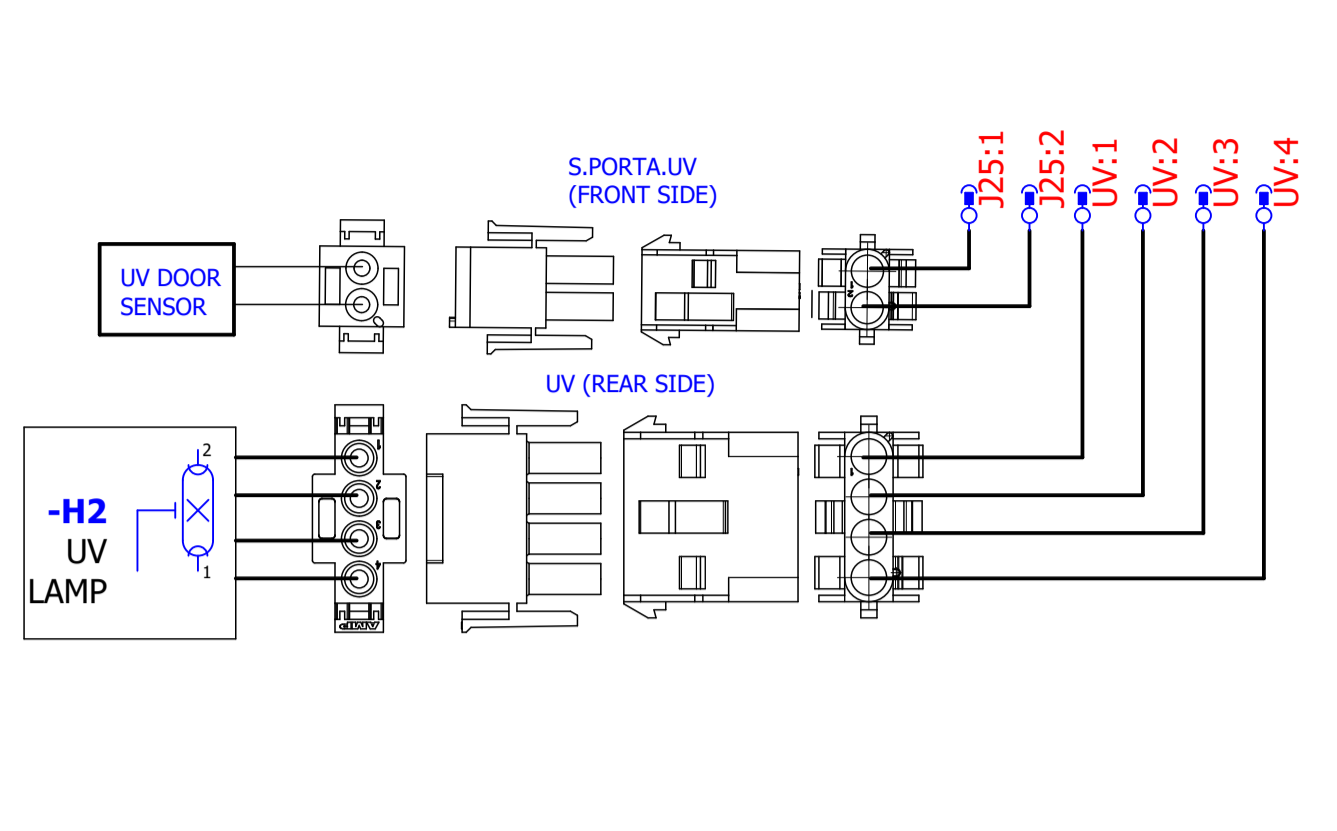

USER INTERFACE

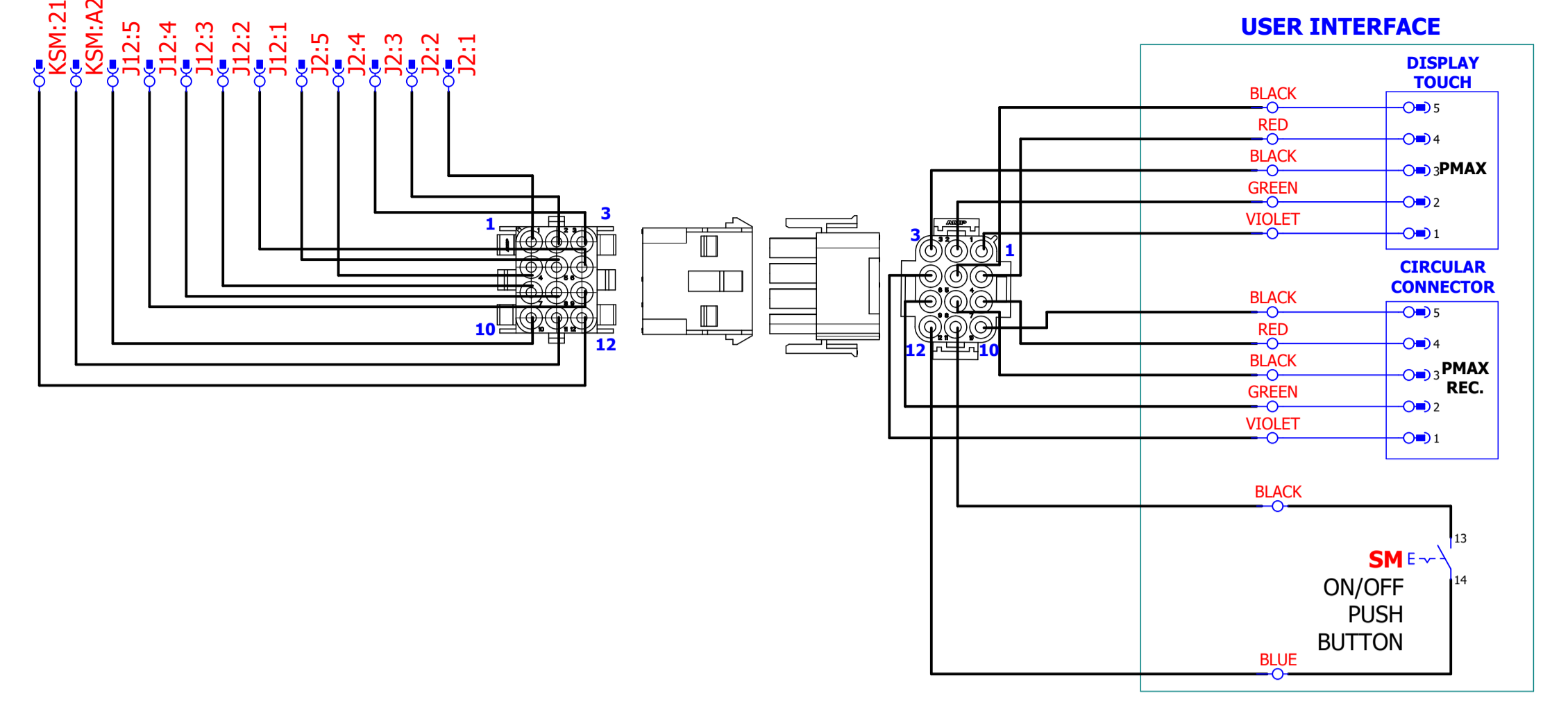

SENSORS

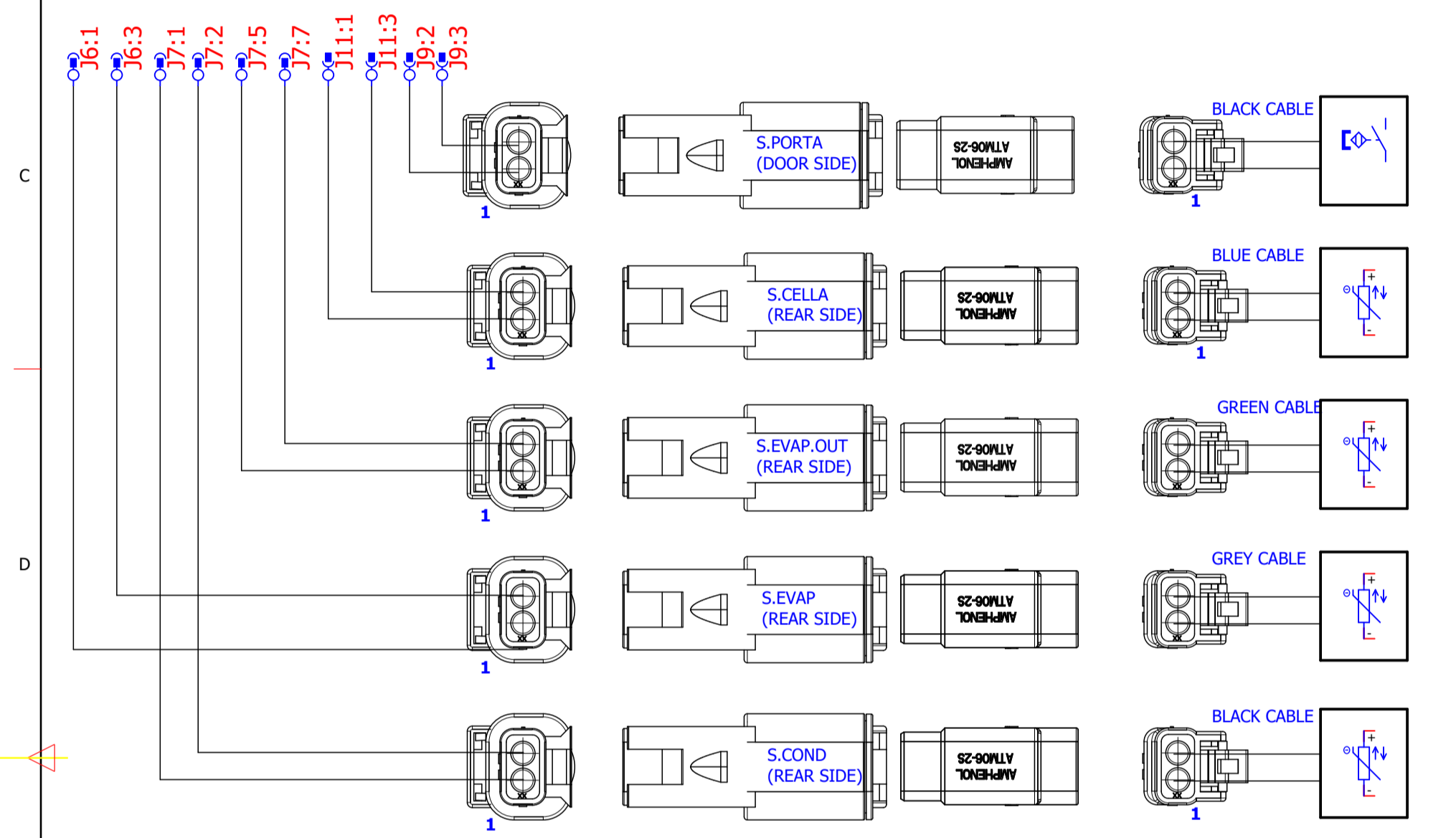

EVAPORATOR FANS

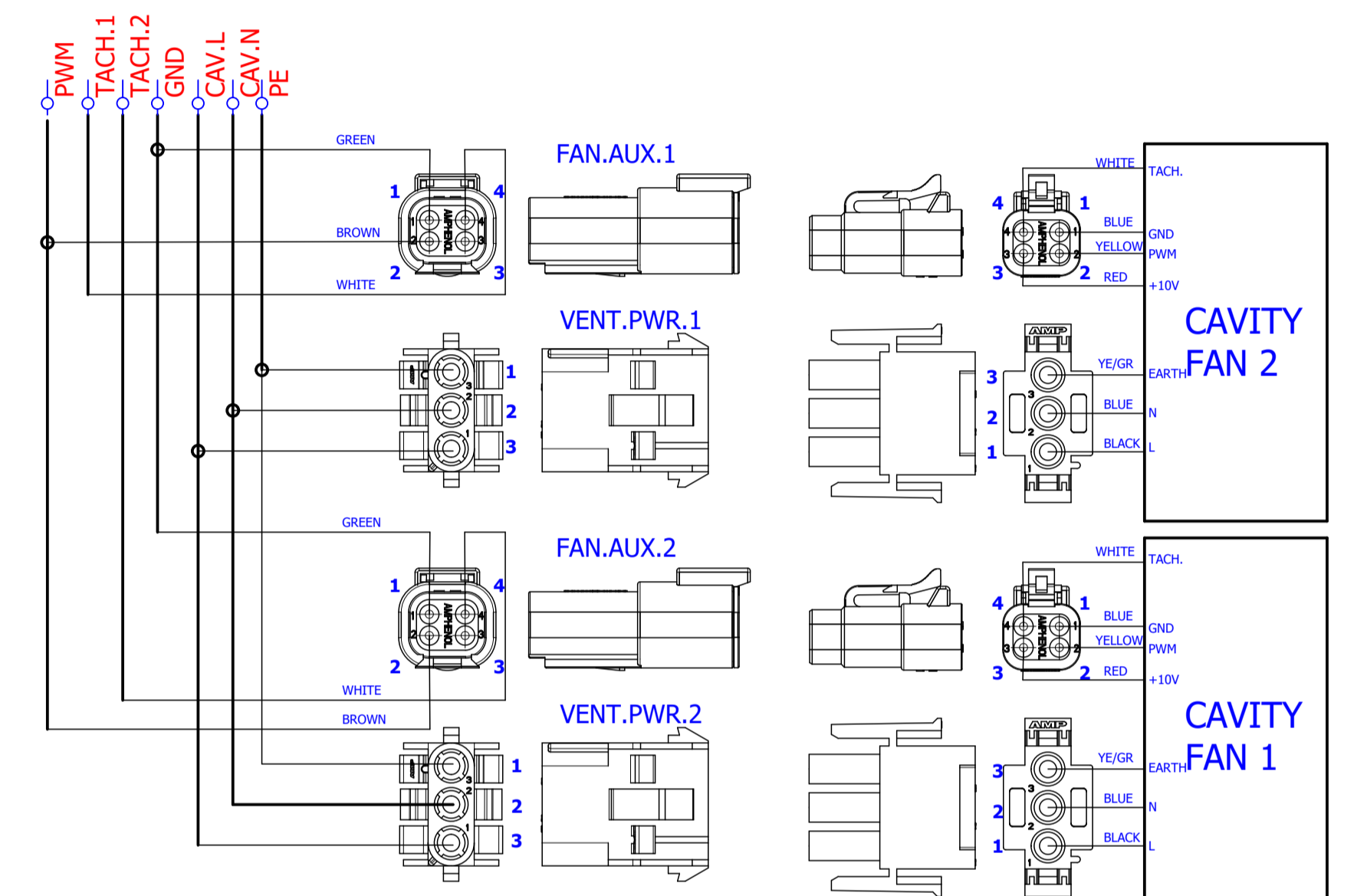

ELECTROVALVES

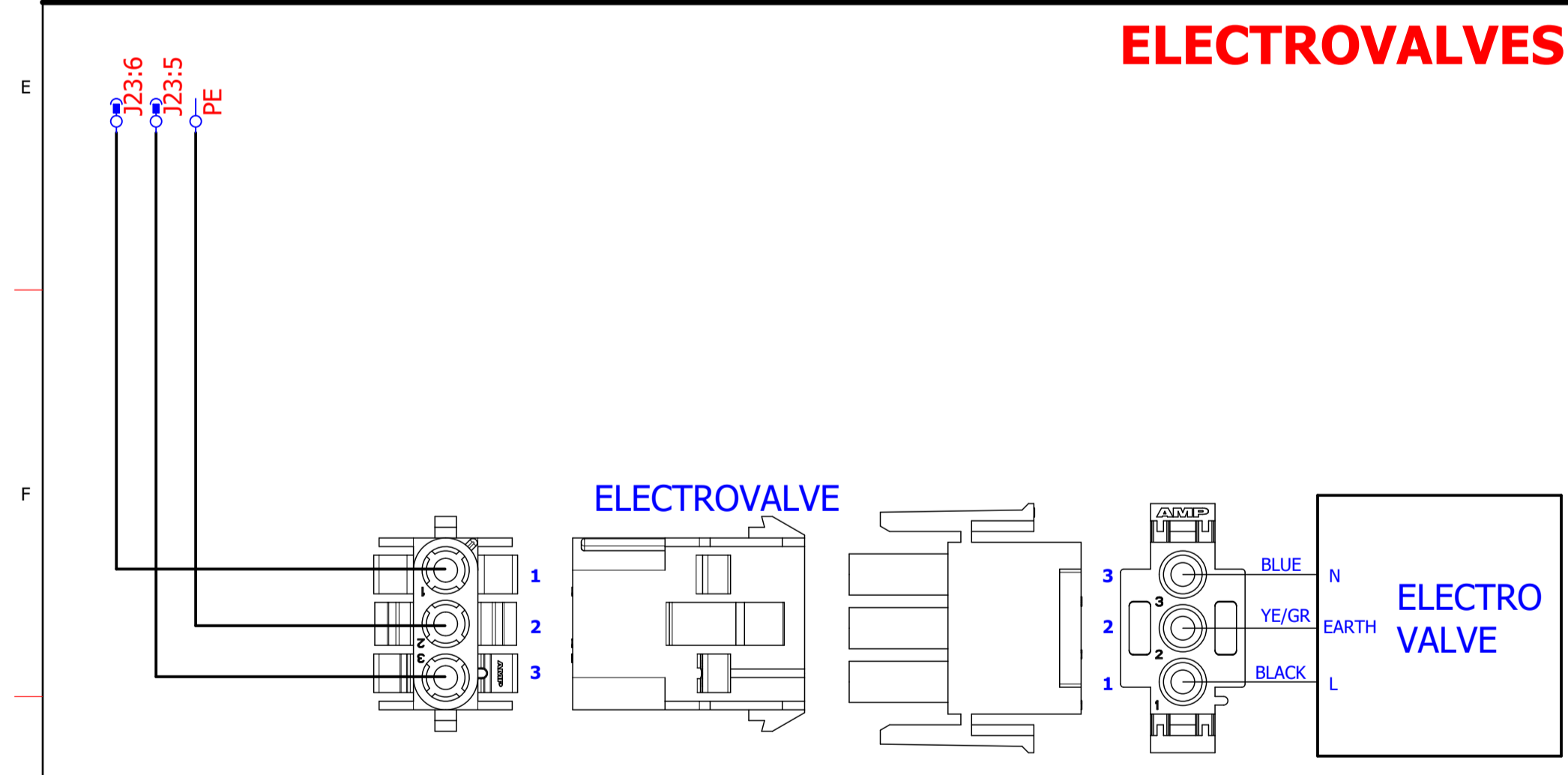

CONDENSER FANS

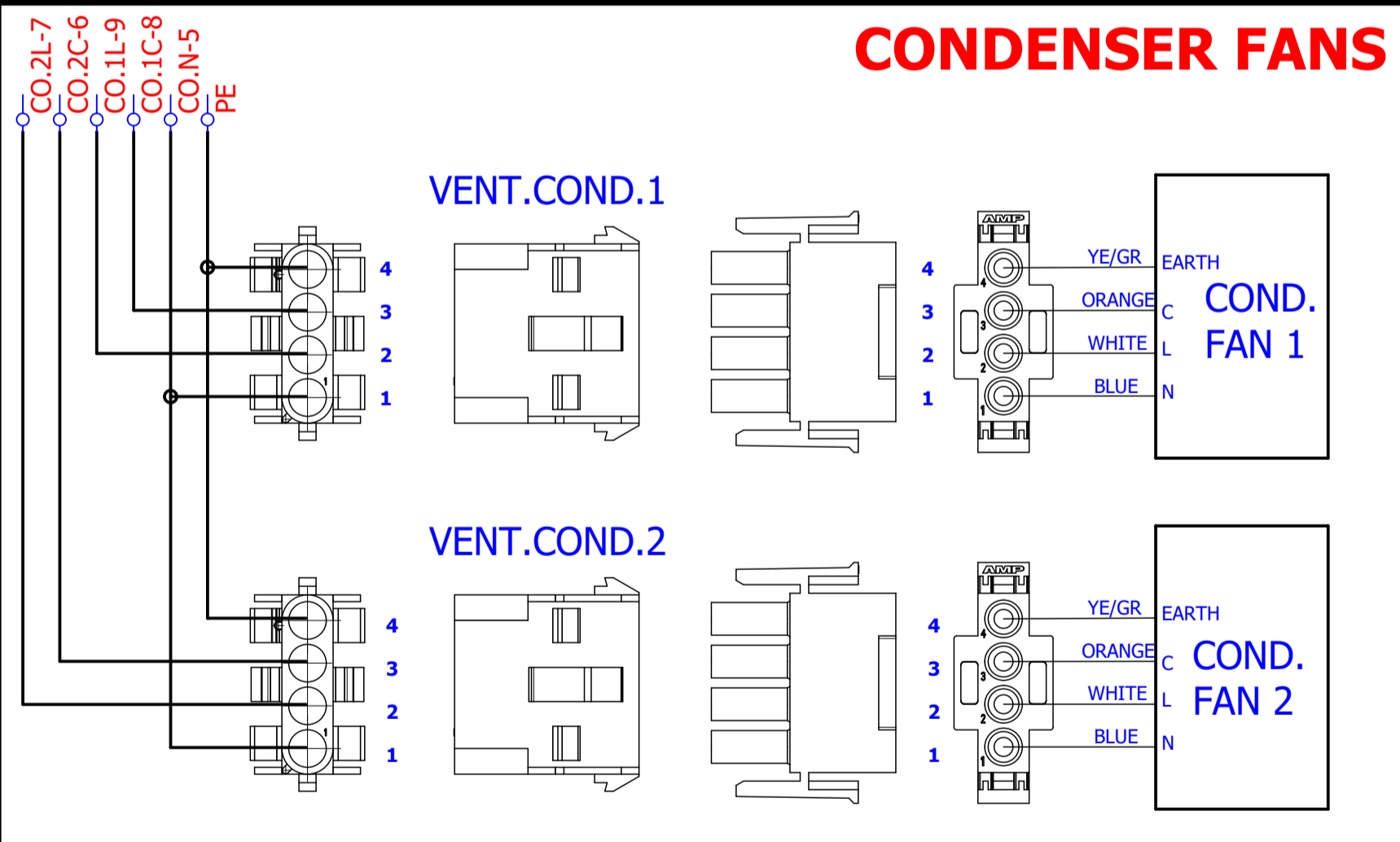

HEATING ELEMENTS

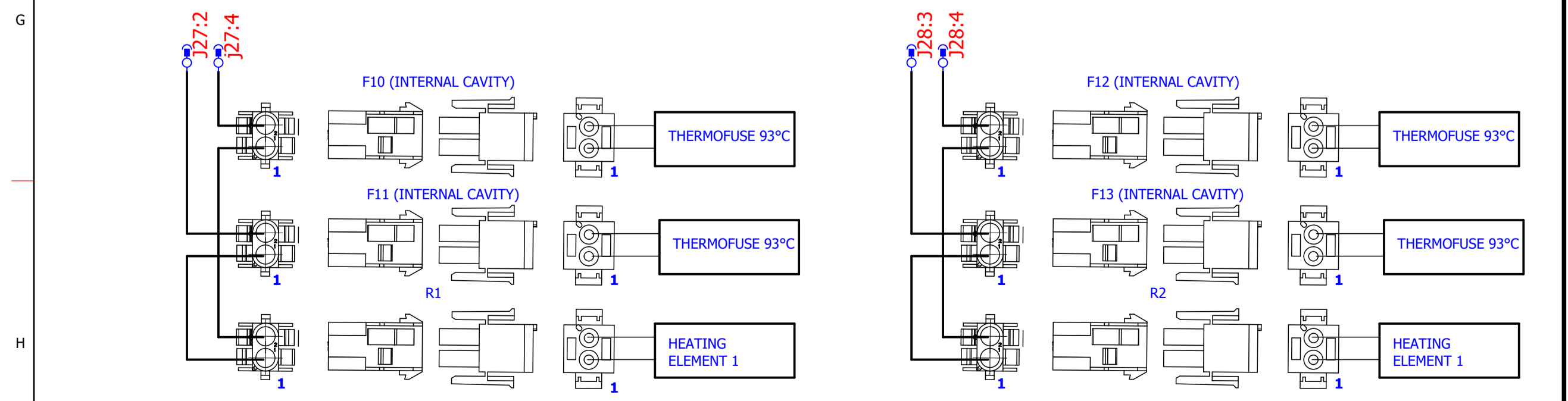

DOOR FRAME HEATING ELEMENTS

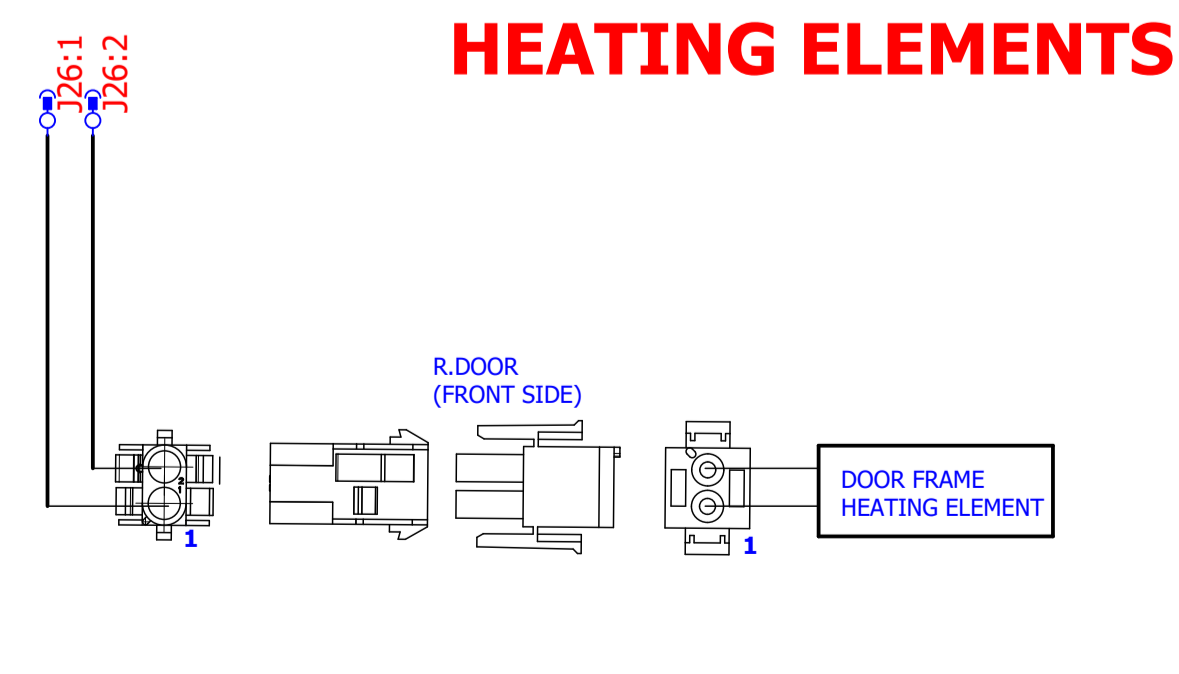

LEGEND

ACU	MAIN BOARD
AL	12Vdc POWER SUPPLY
AL.UV	UV POWER SUPPLY (OPTIONAL)
COMP.	COMPRESSOR
ELV.1	ELECTROVALVE
F1	NEUTRAL FUSE
F2	LINE FUSE
F3	RFI FILTER
FAN.1	CAVITY FAN UP
FAN.2	CAVITY FAN DOWN
FOOD PROBE X-Y	FOOD PROBE SENSOR (X=1,2 Y=1,2,3,4,5,6)
Hx	UV LAMP (OPTIONAL)
KM1	MANUAL MOTOR PROTECTOR (COMPRESSOR)
KM2	CONTACTOR COMPRESSOR (WORK)
KSM	ACTIVATION AUXILIARY RELAY
R1	DEFROST HEATING ELEMENT 800W
R2	DEFROST HEATING ELEMENT 800W
R10	THERMOFUSE 93°C
R11	THERMOFUSE 93°C
R12	THERMOFUSE 93°C
R13	THERMOFUSE 93°C
R20	DOOR FRAME HEATING ELEMENT 230V 10W/m
R.DOOR	47 OHM RESISTANCE
S.CELLA	CAVITY SENSOR
S.COND	CONDENSER SENSOR
S.EVAP	EVAPORATOR SENSOR
S.EVAP.OUT	EXTERNAL EVAPORATOR SENSOR
S.PORTA	DOOR SENSOR
S.PORTA.UV	UV DOOR SENSOR (OPTIONAL)
SM	ON/OFF PUSH BUTTON
VENT.COND.1	CONDENSER FAN 1
VENT.COND.2	CONDENSER FAN 2